



5/2-Way Double Valves with CROSSMIRROR[®] Sensing



1. Of or pertaining to air
or other gases, 2. Run by or using
compressed air, 3. Filled with air,
esp. compressed air.

ROSS safety-related technology has a long tradition...

For almost 40 years ROSS has been developing double valves which have made a significant contribution to the operating safety of pneumatically controlled presses. During this period our range of double valves has been developed continuously in response to the needs of press manufacturers and users. Monitoring devices have also been offered in a variety of designs to satisfy different requirements.

The range of double valves in 5/2-way configuration featuring the all-new CROSSMIRROR®-sensing system presented in this leaflet incorporates all our experience and represents the state-of-the-art in ROSS double valves.

Selecting the double valve best suited to each application requires considerable technical knowledge. If you need further information or technical advice, please contact ROSS or your nearest ROSS distributor or sales office.

CAUTION: *On mechanical presses and other hazardous machines with pneumatically operated clutches and brakes double valves at least should be used. Double valves without self-monitoring should be used only if current regulations permit.*

If the valves are used on presses in Germany, the „Safety Regulations For Control Systems On Power-driven Presses for Metalworking zH 1/457“ must be observed.

For applications not covered by standard valves, please consult ROSS. We reserve the right to make technical modifications in the course of further product development.

ROSS 5/2-way Double Valves with CROSSMIRROR®-Sensing

This all-new ROSS-Crossflow double valve with CROSSMIRROR®-sensing is a 5/2-way valve with two individual solenoid pilot valves each actuating its own individual metal-spool-sleeve valve element.

The spool-and-sleeve valve elements are arranged in parallel design and - as a safety-related feature - they are connected by „crossflow“ channels. In case of normal valve operation both spools move synchronously; when de-actuated, the spools are in the upper position; and when actuated, they are in the lower position. Because of their redundant design and their self-monitoring capabilities, ROSS 5/2-way-Crossflow double valves with CROSSMIRROR®-sensing provide a very high safety standard for the control of single- or double acting cylinders or rotary drives.

Additional safety features are incorporated in the base. In the event of loss of air pressure at the inlet port a check valve is installed to trap the downstream air, a small bleed orifice slowly relieves the trapped air. Additionally a small two-way valve provides safety in the case where inlet pressure is restored whilst the solenoids are still energized. To guard against any sudden cylinder movement, this valve provides a path to exhaust for one of the pilot valves which puts the valve into an inoperable state until both solenoids have been de-energized.

The new ROSS **CROSSMIRROR®-sensing system** is designed to exhaust the pilot supply to one solenoid pilot when only one half of the valve is in an actuated position. This is accomplished by connecting the pilot air supply system to the main valve spool and sleeve. The connection is made such that as the spool moves toward the actuated position the pilot supply is vented to exhaust via the second valve element. When the second valve element moves to the actuated position, it blocks the exhausting pilot air thereby maintaining a constant supply. Pilot supply to the opposite pilot is connected in a mirror image of the first pilot supply, hence the name „cross mirror“.

CONTENTS:

Product description	Page 2
Specifications, model numbers	Page 3
Dimensions	Page 4
Replacement parts	Pages 5, 6
Flow characteristics, valve response times ...	Page 7
General information	Page 8
Cautions	Pages 9, 11
Operating instructions	Page 10

5/2-Way Double Valves with CROSSMIRROR®-Sensing



SPECIFICATIONS

Design: Metal-to-metal spool-and-sleeve valves, pressure-operated. Air and spring returned.

Operation: Solenoid-operated air-piloted valves, 3/2-way-spring-return.

Media²⁾: compressed air, dehydrated, filtered (5 µm), lubricated or unlubricated.

Operating pressure: 2,5 to 10 bar.

Temperature range: 4° C to 50° C.

Mounting orientation: preferably vertically.

Monitoring¹⁾: dynamically, cyclically, internally.

Pilot solenoid: according to VDE 0580. Enclosure rating acc. to DIN 400 50 IP 65. Connector socket according to DIN 43650 Form A.

Solenoids rated for continuous duty.

Standard voltages:
24 V DC 110 V DC
24 V 50 Hz, 110 V 50 Hz, 230 V 50 Hz;
24 V 60 Hz, 110 V 60 Hz, 240 V 60 Hz.

Power consumption:
DC solenoids - 5,3 W
AC solenoids - 8,5 VA

The double valves listed have been approved by the following testing and certificating authority:
BG-Fachausschüsse Eisen und Metall III und Hebezeuge II, Deutschland: Certificate No. 99035

Double Valve

Nominal Diameter	Size	Operating pressure (bar)		Weight (kg)	Type	Model Number ³⁾ (with sub-base)	Replacement valve ³⁾ (without sub-base)
		min.	max.				
10	G 3/8	2,5	10	3,8	CM 5/2	D7776A3410	7776A3400
10	G 3/8	2,5	10	3,9	CM 5/2 with pressure switch	D7776A3411	7776A3401
15	G 1/2	2,5	10	4,8	CM 5/2	D7776A4420	7776A4400
15	G 1/2	2,5	10	5,1	CM 5/2 with pressure switch	D7776A4421	7776A4401
15	G 3/4	2,5	10	4,8	CM 5/2	D7776A5410	7776A4400
15	G 3/4	2,5	10	5,1	CM 5/2 with pressure switch	D7776A5411	7776A4401

Sub-base

Nominal Diameter	Pipe size					Weight (kg)	Design Feature	Model Number
	1	2	3	4	5			
10	G 1/2	G 3/8	G 3/8	G 3/8	G 3/8	1,1	Sub-base is equipped with check valve in pipe connection 1 and 2/2-way valve as reset after pressure energy failure	D996C91
10	1/2 NPT	3/8 NPT	3/8 NPT	3/8 NPT	3/8 NPT	1,1		996C91
15	G 3/4	G 1/2	G 1/2	G 1/2	G 1/2	1,6		D1049C91
15	3/4 NPT	1/2 NPT	1/2 NPT	1/2 NPT	1/2 NPT	1,6		1049C91
15	G 3/4	G 3/4	G 3/4	G 3/4	G 3/4	1,6		D1153C91
15	3/4 NPT	3/4 NPT	3/4 NPT	3/4 NPT	3/4 NPT	1,6		1153C91

Notes

1) In addition, a pressure-switch-monitored model of this valve is available. In case of a malfunction or pressure failure, the pressure switch can be used for signaling abnormal operation. **Important Note:** The pressure switch is not designed to be integrated in a safety circuitry as its response may be delayed, depending on the type of malfunction.

2) It is recommended to use compressed air, filtered and unlubricated. If lubricated air must be used, we recommend oils conforming to ISO viscosity classes 32-46 (DIN 51519).

3) When ordering the valve, specify AC or DC voltage and frequency for operating the pilot solenoids (see Specifications above).



5/2-Way Double Valves with CROSSMIRROR[®]-Sensing

Dimensions – Valve with ported sub-base

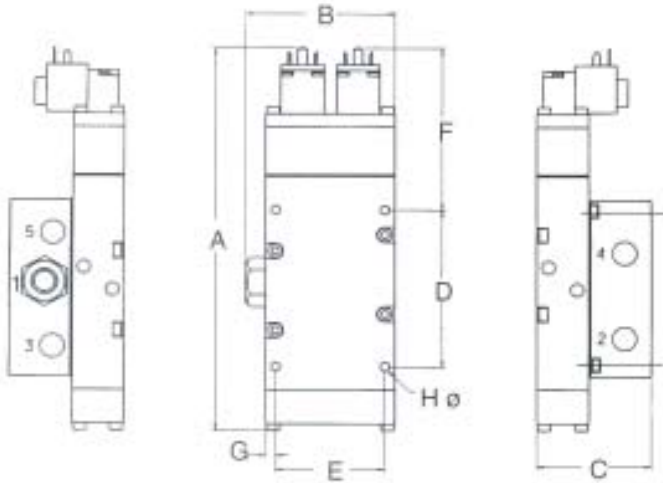

Dimensions – Valve with ported sub-base and pressure switch

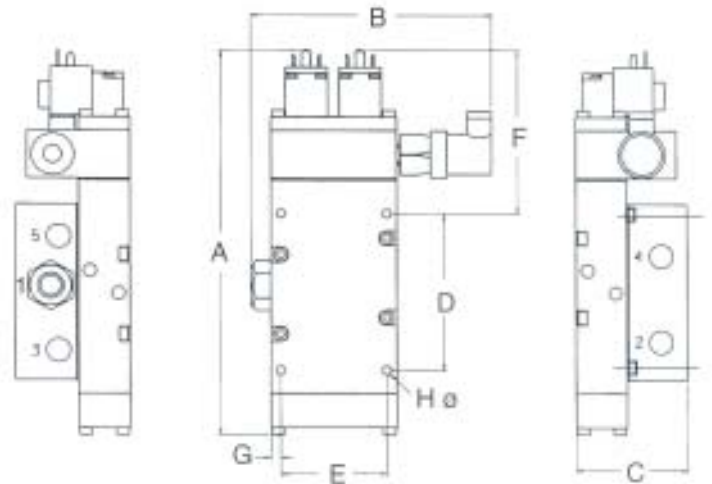

Dimensional drawings:

Mounting interface sub-base to machine
dimensions: D; E; F; G and H

Dimensions in mm

	A	B	C	D	E	F	G	H \varnothing
Double valve with ported sub-base								
ND 10	282	104	81	115,6	75	119,5	7	7 or M 6
ND 15	310	108	106	136	81	122	7	7 or M 6
Double valve with ported sub-base and pressure switch								
ND 10	282	172	81	115,6	75	119,5	7	7 or M 6
ND 15	310	175	106	136	81	122	7	7 or M 6

5/2-Way Double Valves with CROSSMIRROR®-Sensing

Replacement parts –
Valve with pressure switch

Valve Numbers
7776A3401
7776A4401

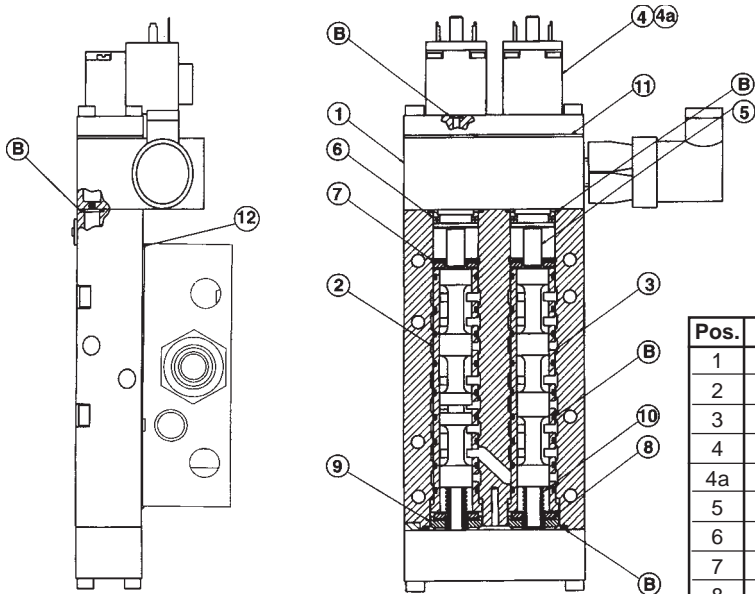

Pos.	Qty.	7776A3401	7776A4401	Description
1	1	854C89	883C89	Sensing assembly
2	1	420H90	418A90	Inlet spool/sleeve
3	1	421H90	419A90	Outlet spool/sleeve
4	2	1044H79	1044H79	Pilot assembly
4a	2	–	–	Coil
5	2	577A09	603A09	Actuation piston
6	2	583A32	503A32	Seal
7	2	139J22	143J22	Retaining ring
8	4	288A32	289A32	Bumper
9	2	1460A25	1585A25	Spacer
10	2	478A13	497A13	Compression spring
11	1	860A11	886A11	Gasket (pilot-to-body)
12	1	861A11	885A11	Gasket (body-to-sub-base)
B	1	1575K77	1577K77	Seal kit

Pressure switch assembly

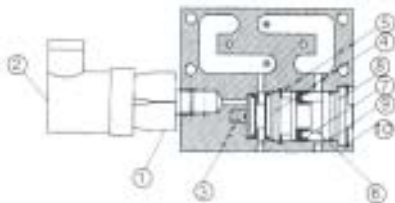

Pos.	Qty.	854C89	883C89	Description
1	1	518E30	518E30	Pressure switch
2	1	522E30	522E30	Connector socket
3	1	207A13	207A13	Spring
4	1	200A97	200A97	Insert assy.
5	1	144J22	144J22	Retaining ring
6	1	580A09	580A09	Piston
7	1	768J32	768J32	U-cup seal
8	1	678B25	678B25	Stem guide
9	1	207J15	207J15	O-Ring
10	1	131J22	131J22	Retaining ring

Sub-base assembly

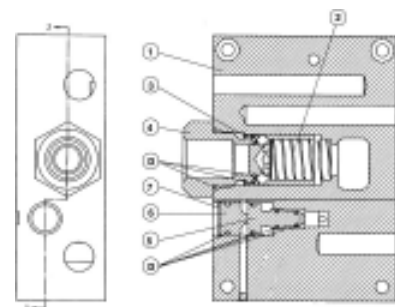

Pos.	Qty.	D996C91	D1049C91 D1153C91	Description
1	1	D1048B91	D1130B91	Valve body assembly
2	1	488A13	222A13	Spring
3	1	185A88	351A88	Valve poppet assembly
4	1	D332B85	D334B85	Check valve assembly
5	1	147A90	147A90	Spool assembly
6	1	157A85	157A85	Plug assembly
7	1	133J22	133J22	Retaining ring
D	1	1576K77	1578K77	Seal kit



5/2-Way Double Valves with CROSSMIRROR®-Sensing

Replacement parts –
Valve without pressure switch

Valve Numbers
7776A3400
7776A4400

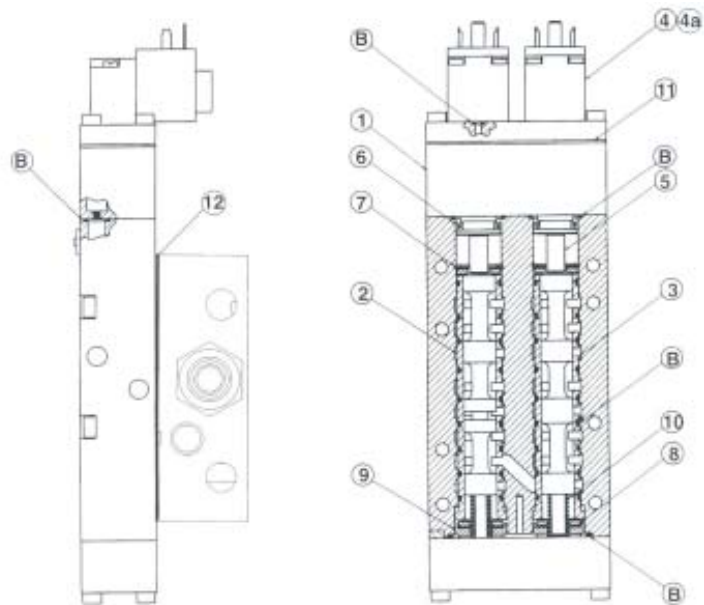

Pos.	Qty.	7776A3400	7776A4400	Description
1	1	853C89	884B89	Sensing assembly
2	1	420H90	418A90	Inlet spool/sleeve
3	1	421H90	419A90	Outlet spool/sleeve
4	2	1044H79	1044H79	Pilot valve assembly
4a	2	–	–	Coil
5	2	577A09	603A09	Actuating piston
6	2	583A32	503A32	Seal
7	2	139J22	143J22	Retaining ring
8	4	288A32	289A32	Bumper
9	2	1460A25	1585A25	Spacer
10	2	478A13	497A13	Compression spring
11	1	860A11	886A11	Gasket (pilot-to-body)
12	1	861A11	885A11	Gasket (body-to-sub-base)
B	1	1575K77	1577K77	Seal kit

Sub-base assembly

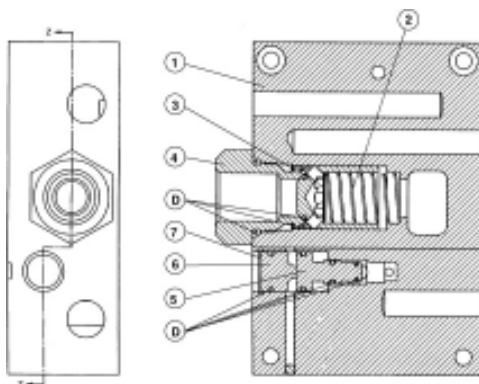

Pos.	Qty.	D996C91	D1049C91 D1153C91	Description
1	1	D1048B91	D1130B91	Valve body assembly
2	1	488A13	222A13	Spring
3	1	185A88	351A88	Valve poppet assembly
4	1	D332B85	D334B85	Check valve assembly
5	1	147A90	147A90	Spool assembly
6	1	157A85	157A85	Plug assembly
7	1	133J22	133J22	Retaining ring
D	1	1576K77	1578K77	Seal kit



5/2-Way Double Valves with CROSSMIRROR[®]-Sensing

Flow characteristics (k_v-values)

Flow direction	k _v - values					
	Valve No.: 7776A3400 & 7776A3401 with sub-base D996C91 Inlet G 1/2; Outlet G 3/8			Valve No.: 7776A4400 & 7776A4401 with sub-base D1049C91 Inlet G 3/4; Outlets G 1/2 - G 3/4		
	Normal	Function Abnormal Side „A“ Side „B“		Normal	Function Abnormal Side „A“ Side „B“	
1 to 2	1,8	1,4	1,8	2,78	2,0	2,78
1 to 4	1,5	–	–	2,95	–	–
2 to 3	1,4	–	–	2,34	–	–
4 to 5	2,4	1,8	1,8	6,26	3,65	3,13

Valve response times

Valve No.: 7776A3400 and 7776A3401 5/2 Nominal diameter 10
7776A4400 and 7776A4401 5/2 Nominal diameter 15

Solenoid operated: 230V / 50Hz

Test pressure: 3; 6 bar

Work ports 2 and 4 are closed without volume.

	Flow direction	Pressure	Response times in ms ¹⁾							
			7776A....				7776A....			
			3400 3401 3 bar		3400 3401 6 bar		4400 4401 3 bar		4400 4401 6 bar	
ENERGIZED Normal function	1 to 4	rising	34	40	25	28	47	41	34	35
	2 to 3	falling	30	34	26	27	45	38	35	31
DE-ENERGIZED Normal function	1 to 2	rising	29	44	44	39	61	62	60	60
	4 to 5	falling	38	39	40	37	59	57	62	62
ENERGIZED Abnormal function Side A ²⁾	1 to 2	rising	50	47	53	46	54	59	70	63
	4 to 5	falling	45	50	52	49	50	56	56	57
ENERGIZED Abnormal function Side B ³⁾	1 to 2	rising	41	47	46	57	64	56	52	52
	4 to 5	falling	28	54	47	53	61	57	55	67

1) Response time: ENERGIZED - average time required to fill volume to 90% of supply pressure.
DE-ENERGIZED - average time required to exhaust volume to 10% of supply pressure.

2) 3) In case of malfunctions due to differing actuation functions of pilot valves or/and the main valve systems of valve side A or B.



5/2-Way Double Valves with CROSSMIRROR®-Sensing

GENERAL INFORMATION

The new ROSS 5/2-way CROSS MIRROR® double valve is designed as a self-monitoring valve. It can be used for controlling pneumatic presses for cold-forming of metal (optionally in connection with additional devices such as pilot-operated check valves), if the electric control of the valve is designed in accordance with prEN... "Pneumatic Presses" (June 1998). The mirror-image-type air flow pattern in the CROSS MIRROR® double valve allows an alternating pressure buildup from the de-actuated (pressure port 1 to work port 2) to the actuated mode (pressure port 1 to work port 4) only if the following conditions are fulfilled:

1. The solenoid control signals must actuate the solenoid pilot valves synchronously or with a time difference of < 0,5 sec.
2. Both main valve systems must be in the at-rest position before the valve is actuated.
3. Both main valve systems must have moved into the actuated position within a defined time span of < 0,5 sec.

Additional work-safety features are incorporated in the base:

1. A check valve in the inlet port prevents the cylinder from falling abruptly when a loss of pressure occurs. In such a case a small bypass will allow the cylinder to move gradually into the at-rest-position.
2. When an unexpected loss of pressure occurs with the electric pilot signal still being present, another valve integrated in the sub-base is designed to prevent any uncontrolled valve shifting and cylinder movement that might occur when the pressure returns. In case of a pressure loss this valve opens the pilot air line and thereby prevents the main valve system from shifting when pressure returns. All pilot valves and main valve systems must be in the at-rest-position before a restart of the system after a pressure loss.

Pressure Switch Unit (optional)

In case of a valve malfunction, the standard valve shifts back to the at-rest-position; i.e. pressure from port 1 to port 2. By actuating the valve again, the cause of the malfunction (dirt or asynchronous signals) can be eliminated and the valve can operate normally again. In order to detect such a malfunction, a valve with pressure switch unit is available.

This pressure switch unit can be used to signal a malfunction and to interrupt valve piloting. Properly wired into the electric circuit, the pressure switch can prevent a new valve cycle until the malfunction has been analyzed and eliminated.

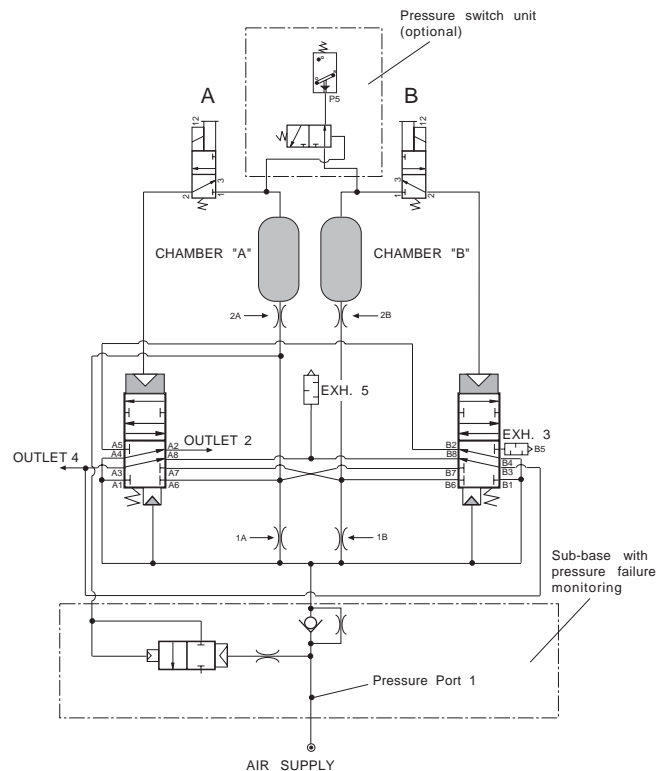

**Schematic
(Valve in the de-actuated position)**

5/2-Way Double Valves with CROSSMIRROR®-Sensing

CAUTIONS

Installation

Double valves should be installed only by persons trained and experienced in the installation of such equipment.

Lines

Air supply directed through air preparation units and pressure regulator to pressure port 1 requires minimum line capacity of pressure port 1.

Lines and line connections must be in accordance with relevant safety regulations, e.g. prEN... Pneumatic Presses“ (June 1998).

Cylinder speed regulation

When installing components between the double valve and the work element, the relevant safety regulations e.g. prEN... Pneumatic Presses“ (June 1998) need to be observed.

Air preparation

An efficient filter unit (at least 5 µm) must be mounted before the valve. Use of a lubricator is not necessary if the work element is designed for non-lube operation.

Silencers

Silencers can be mounted to ports 3 and 5 of the double valve. These must be in accordance with the

relevant safety regulations, as for instance prEN... Pneumatic Presses“ (June 1998). *Restricting the exhaust port of a double valve can adversely affect its proper operation. Silencers must be resistant to clogging and have a flow capacity larger than the exhaust capacity of the valve.*

Piloting

Electrical piloting of the double valve must be in accordance with the relevant (application-specific) safety regulations.

SAFETY-RELEVANT CAUTIONS:

- The use of surge suppressors in the solenoid circuits may slow down the de-energisation of the solenoid coils and thereby may delay response of the valve elements which may increase exhaust time.
- Depending on the application, the electrical connection with the valve may have to be secured separately.
- In case of machine vibration > 25g a suitable shock absorbing mounting device has to be provided for the valve.

Mounting schematic (example)

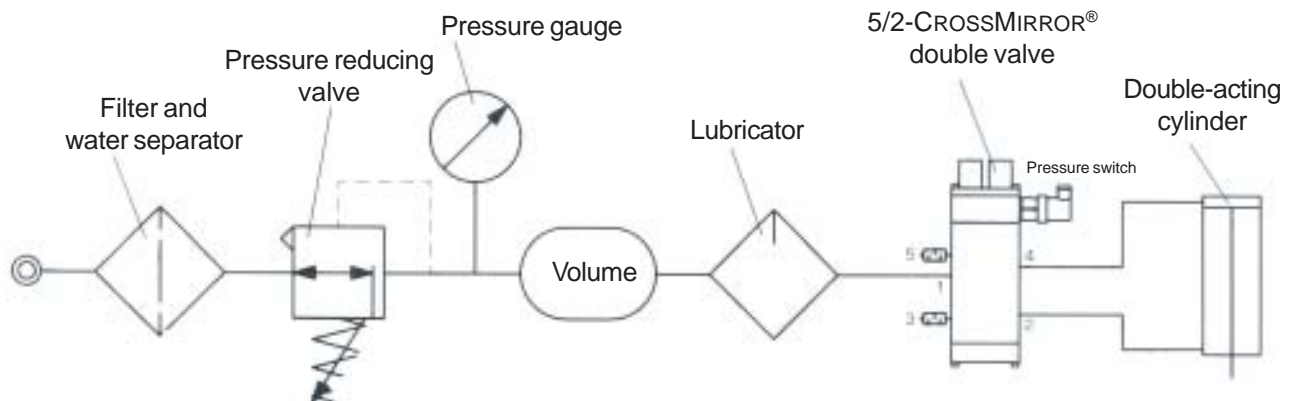

5/2-Way Double Valves with CROSSMIRROR®-Sensing

OPERATING INSTRUCTIONS

Start-up

Prior to start-up, the installation must be checked thoroughly by persons trained and experienced in the operation of pneumatic equipment. Make sure that the maximum operating pressure specified on the valve label will not be exceeded. When operating pressure is applied, the cylinder piston must move into the at-rest-position. For further testing, a **functional test** as well as a **pressure failure test** must be performed.

Functional test

Test	Result
1. Actuate solenoid A	Piston does not move
2. Actuate solenoid B	Piston does not move
3. Actuate solenoid A, then actuate solenoid B after $t > 0,5s$	Piston does not move
4. Actuate solenoid B, then actuate solenoid A after $t > 0,5s$	Piston does not move
5. Actuate solenoids A and B after $t < 0,5s$ then de-energize solenoid A and re-actuate after $t > 0,5s$	Piston moves, but returns to at-rest-position after solenoid A is de-energized, and remains in that position
6. As under 5., however, test to be performed with solenoid B	See result 5

Pressure failure test

The valve is in the at-rest position. Turn off operating pressure at port 1 and exhaust the operating pressure line. Actuate the valve in the normal way (solenoids A and B in $t < 0,5s$), and keep the solenoids energized. Then apply operating pressure to port 1 again. The piston is not supposed to leave its position. For checking the check valve in port 1, close and exhaust the operating pressure line. If the check valves close properly, the piston will not move downward quickly. Depending on the intensity of usage, the check valves should be checked at three month' intervals.

Malfunctions

In case of malfunctions, we recommend to check/ exchange the double valve immediately.

Maintenance, testing

Maintenance and testing procedures must follow the rules and guidelines set by the respective nati-

onal work-safety institutions. These procedures should only be performed by persons trained and experienced in the use of pneumatic equipment. It is recommended that maintenance and test procedures be performed at least once a year, unless otherwise specified.

Repair

It is recommended that double valves which need to be serviced be handed over to a ROSS service point. Customers maintaining their own repair service have to make sure that only original spare parts (as specified in the ROSS parts lists) be used. Pneumatic equipment should be repaired only by persons trained and experienced in the repairing of such equipment, guided by these operating instructions. Information about valve repair and/or the exchange of a valve must be written down in the machine operation documentation.



5/2-Way Double Valves with CROSSMIRROR[®]-Sensing

MUFFL-AIR[®] -Silencers

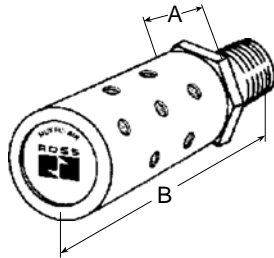
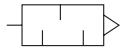

Male thread

Pipe size	ø k _v -value	Model number	Dimensions - mm	
			A	B
R 3/8	5,0	D5500A3003	32	96
R 1/2	6,1	D5500A4003	32	96
R 3/4	6,1	D5500A5013	32	96

Cautions

PRE-INSTALLATION or SERVICE

1. Before servicing a valve or other pneumatic component, be sure that the electrical supply is turned off and that the entire pneumatic system is shut off and exhausted.
2. All ROSS products, including service kits and parts, should be installed and/or serviced only by persons having training and experience with pneumatic equipment. Because any installation can be tampered with or need servicing after installation, persons responsible for the safety of others or the care of equipment must check every installation on a regular basis and perform all necessary maintenance.
3. All applicable instructions should be read and complied with before using any fluid power system in order to prevent harm to persons and/or equipment. In addition, overhauled or serviced valves must be functionally tested prior to installation and use.
4. Each ROSS product should be used within its specification limits. In addition, use only ROSS parts to repair ROSS products. Failure to follow these directions can adversely affect the performance of the product or result in the potential for human injury.

FILTRATION and LUBRICATION

5. Dirt, scale, moisture, etc. are present in virtually every air system. Although some valves are more tolerant of these contaminants than others, best performance will be realized if a filter is installed to clean the air supply, thus preventing contaminants from interfering with the proper performance of the equipment. ROSS recommends a filter with a 5-micron rating for normal applications.
6. All standard ROSS filters and lubricators with polycarbonate plastic bowls are designed for compressed air applications only. Do not fail to use the metal bowl guard, where provided, to minimize danger from high pressure fragmentation in the event of bowl failure. Do not expose these products to certain fluids, such as alcohol or liquified petroleum gas, as they can cause bowls to rupture, creating a combustible condition, hazardous leakage, and the potential for human injury. Immediately replace a crazed, cracked or deteriorated bowl. When the bowl gets dirty, replace it or wipe it with clean dry cloth.

7. Only use lubricants which are compatible with materials used in the valves and other components in the system. Normally, compatible lubricants are petroleum base oils with oxidation inhibitors, an aniline point between 82°C and 104°C, and an ISO 32, or lighter, viscosity. Avoid oils with phosphate type additives which can harm polyurethane components, potentially leading to valve failure and/or human injury.

AVOID INTAKE / EXHAUST RESTRICTION

8. Do not restrict the air flow in the supply line. To do so could reduce the pressure of the supply air below the minimum requirements for the valve and thereby cause erratic action.
9. Do not restrict a poppet valve's exhaust port as this can adversely affect its operation. Exhaust silencers must be resistant to clogging and have flow capacities at least as great as the exhaust capacities of the valves. Contamination of the silencer can result in reduced flow and increased back pressure. *ROSS expressly disclaims all warranties and responsibility for any unsatisfactory performance or injuries caused by the use of the wrong type, wrong size, or inadequately maintained silencer installed with a ROSS product.*

DOUBLE VALVES

10. Mechanical power presses and other potentially hazardous machinery using a pneumatically controlled clutch and brake mechanism must use a press control double valve with a monitoring device. A double valve without a self-contained monitoring device should be used only in conjunction with a control system which assures monitoring of the valve. All double valve installations involving hazardous applications should incorporate a monitoring system which inhibits further operation of the valve and machine in the event of a failure within the valve mechanism.



ROSS EUROPA GmbH
Robert-Bosch-Strasse 2
D-63225 Langen / Germany
Phone: +49-6103-7597-0
Fax: +49-6103-74694
www.rosseuropa.com



ROSS CONTROLS®
P.O. Box 7015,
Troy, Michigan 48007 U.S.A.
Phone: +1-248-764-1800
Fax: +1-248-764-1850
www.rosscontrols.com

ROSS UK Ltd.
Cakemore Road, Rowley Regis,
Warley, West Midlands, B65 0QW
United Kingdom
Phone: +44-121 559 4900
Fax: +44-121 559 5309
www.rossuk.com

ROSS ASIA K.K.
10209-5 Tana, Sagamihara-shi
Kanagawa-pref. 229-11, Japan
Phone: +81-427-78-7251
Fax: +81-427-78-7256
www.rossasia.co.jp

ROSS SOUTH AMERICA Ltda.
Rua Olavo Goncalves, 43/47 - Centro
Sao Bernardo do Campo - Sao Paulo
Brazil - CEP 09725-020
Phone: +55-11-4335-2200
Fax: +55-11-4335-3888

ROSS CONTROLS INDIA Pvt. Ltd.
Plot 113, Industrial Estate
Ambattur
Chennai 600 058, India
Phone: +91-44-8413136
Fax: +91-44-8413137
www.rossindia.com

ROSS ASIA K.K.-
CHINA LIAISON OFFICE
Room 701, Taiji Building,
No. 33.1249 Street
Xikang Road
Shanghai, China
Phone: +86-21-6296-5123
Fax: +86-21-6299-0529

WARRANTY

Products manufactured by ROSS are warranted to be free of defects in material and workmanship for a period of one year from the date of purchase. ROSS' obligation under this warranty is limited to repair or replacement of the product or refund of the purchase price paid solely at the discretion of ROSS and provided such product is returned to ROSS freight prepaid and upon examination by ROSS is found to be defective. This warranty shall be void in the event that product has been subject to misuse, misapplication, improper maintenance, modification or tampering. The warranty expressed above is in lieu of and exclusive of all other warranties and ROSS expressly disclaims all other warranties either expressed or implied with respect to merchantability or fitness for a particular purpose. ROSS makes no warranty with respect to its products meeting the provisions of any governmental occupational safety and/or health laws or regulations. In no event shall ROSS be liable to purchaser, user, their employees or others for incidental or consequential damages which may result from a breach of the warranty described above or the use or misuse of the products. No statement of any representative or employee of ROSS shall extend the liability of ROSS as set forth herein.